

Bestückungsgerät inkl. Unterteil

für die automatische Verarbeitung
von Massenteilen

Magasin d'alimentation avec pièce inférieure

pour l'insertion automatique des articles
de séries

Applicator with lower part

for automatic insertion
of parts

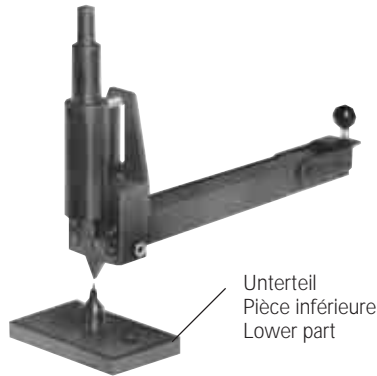

Unterteil
Pièce inférieure
Lower part

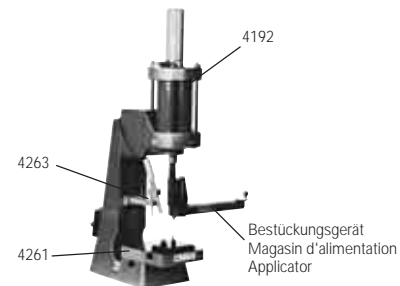

4192
4263
4261
Bestückungsgerät
Magasin d'alimentation
Applicator

Artikel-Nr. Numéro d'article Part-No.	Lötstifte Chevilles de soudure Soldering lugs
1040	01015; 01018
104006	01015/0,6; 01018/0,6
1040 B	01002B
1040 DE	01003D; 01003E
1040 F	01021
1040 G	01002A; 01015E
1040 L	01005L
1040 M	01004L; 01004M
1040 P	01015B; 01015C
1040 Q	01002Q
1040 R	01002P
1040 S	01001S
1040 U	01001U; 01004A
1040 V	01001K; 01001V
1040 W	01001W
1040 Y	01001Y
1042	01016L
1042 A	01016A
1042 B	01016B; 01016V
1042 C	03779C; 03779K
1042 DE	01016D; 01016E
1042 F	01016F
1042 G	01002D
1042 H	03779H; 03779R
1042 K	01016C
1042 L	01016K
1042 M	01016G; 01016H
1042 P	01001P
1042 Q	01001L; 01001Q
1042 R	01016R
1042 S	01016S
1042 T	01016T

Artikel-Nr. Numéro d'article Part-No.	Lötstifte Chevilles de soudure Soldering lugs
1043	01011
1043 C	01002T
1043 D	01004D
1043 G	01001G
1043 H	01005H; 01017H
1043 L	01023L
1043 M	01016M
1043 S	01023S
1043 U	01004U
1043 W	01016W
1044	01007A
1044 B	01004B
1044 C	01007C; 01007D
1044 C06	01007C/0,6
1044 G	01007A/0,8
1044 H	01004H
1044 K	01017
1044 P	01004P
1044 S	01004S
1044 T	01004T
1047 B	01005B
1049	01003
1049 A	01019A
1049 B	01013; 01013E; 01013S
1049 C	01003C
1049 D	01019
1049 E	01019C
1049 F	01099D
1049 G	01019G
1049 K	01099K
1049 L	01003L
1049 M	01019B

Artikel-Nr. Numéro d'article Part-No.	Lötstifte Chevilles de soudure Soldering lugs
1049 P	01022L
1049 S	01022S
1049 T	01023B
1049 U	01099A
1050	01002M
105006	01002M/0,6; 01003M
1050 B	01081L
1050 D	01015D; 01015K
1050 F	01002F; 01002H
1050 K	01002K; 01004C
1050 L	01002L
1050 L08	01004Q
1050 R	01002R
1050 S	01017S
1050 W	01002W; 01003U; 01004V
1064	01009K; 01009L

Artikel-Nr. Numéro d'article Part-No.	Winkelstifte Chevilles angulaires Angle pins
1051 A	01080A
1051 B	01081L
1051 C	01080G
1051 G	01080M/0,8
1051 M	01080M
1051 S	01080S
1051 T	01080T
1051 V	01080V
1051 X	01080X

Bestellbeispiel:
Exemple de commande:
Example of order:
1042 M

